

STAINLESS STEEL CABINETS

HR-ESSTTR18-N | ESSENCE

RECYCLING PULL-OUT DRAWER CABINET

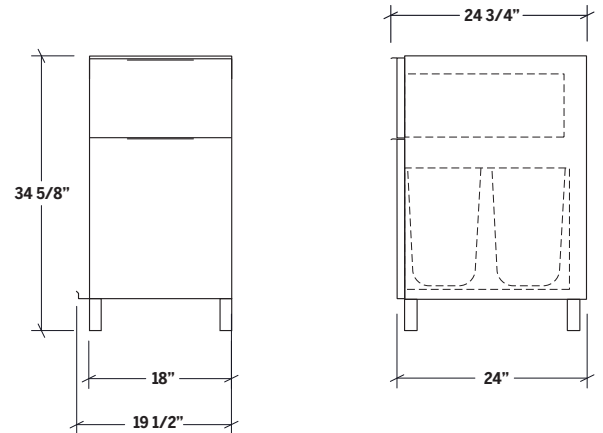

Specifications

Collection	Nature
Width	18"
Depth	24"
Material	Stainless Steel 304
Thickness	18 ga
Finish	Brushed
Nbr doors / drawers	2
Hinges Position	0
Handle	N/A
Installation	Self-Standing

Features

- Recycling pull-out drawer cabinet with two (2) plastic bins for recycling and household garbage. Integrated drawer perfect to store garbage bags and other accessories.
- Modular system to optimize space and create a personalized outdoor kitchen area.
- Self-standing cabinet finished on all 4 sides providing flexible placement in island kitchen style or simply leaned against a wall.
- ESSENCE collection cabinets for a refined and unified look. Elegant brushed finish that matches grills and appliances.
- Soft-close hardware for soft and quiet closing of drawers.
- Superior corrosion resistance thanks to commercial grade 18 gauge 304 (18/10) stainless steel.
- Environmentally friendly product made with 100% recyclable stainless steel.
- Modules are delivered fully assembled.
- Proudly designed and made by hand in Canada.

Warranty

Home Refinements offers a LIMITED LIFETIME WARRANTY on the fixed components of its stainless steel cabinets as well as a 2-YEARS LIMITED WARRANTY for all mobile parts and hardware (Hinges, slides, locks) against defects of material and workmanship all of which is applied following the purchase date. This warranty is limited to defects or damages resulting from a normal residential use. For further details on our product warranty, please refer to our catalog or Web site.